

TRF TYPE

– Triple-Wide Round Flange Type –

This type is a metric dimension series widely used in Japan and other countries.

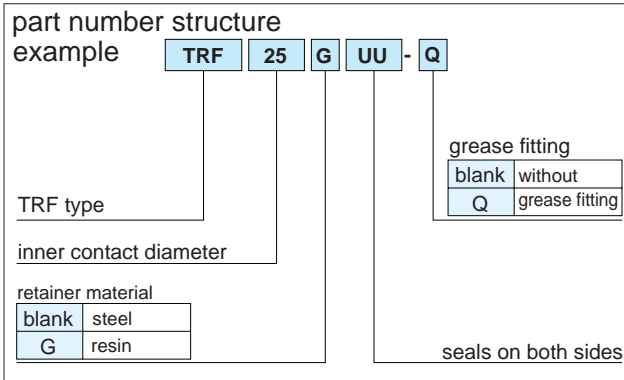
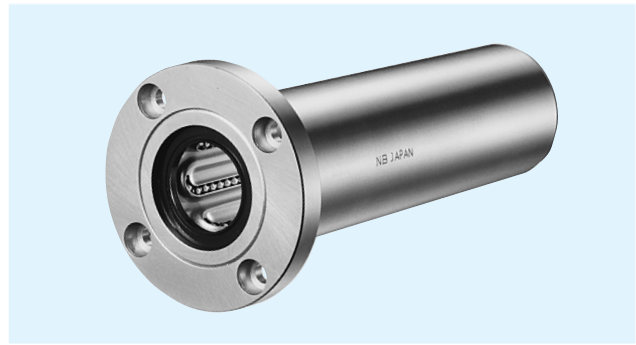

part number*		dr		D		L	Df
steel retainer	resin retainer	mm	tolerance μm	mm	tolerance μm	±0.3 mm	mm
TRF 6UU	TRF 6GUU	6	0	15	0/-18	51	32
TRF 8UU	TRF 8GUU	8	-12	19	0	66	40
TRF10UU	TRF10GUU	10	-15	23		80	43
TRF12UU	TRF12GUU	12		0	26	-21	84
TRF13UU	TRF13GUU	13	-18	28	0	90	48
TRF16UU	TRF16GUU	16		32		103	54
TRF20UU	TRF20GUU	20	0	40	-25	118	62
TRF25UU	TRF25GUU	25	-18	45		165	74
TRF30UU	TRF30GUU	30	0	52	0	182	82
TRF35UU	TRF35GUU	35		60		200	96
TRF40UU	TRF40GUU	40	-21	65	-30	230	101
TRF50UU	TRF50GUU	50	0/-25	85	0	290	129
TRF60UU	TRF60GUU	60		100	-35	310	144

* UU type is standard feature.

** Outer cylinder is treated with electroless nickel plating.

*** TRF6-8: A-MT6x1 TRF10-30: A-M6F TRF35-60: A-PT1/8

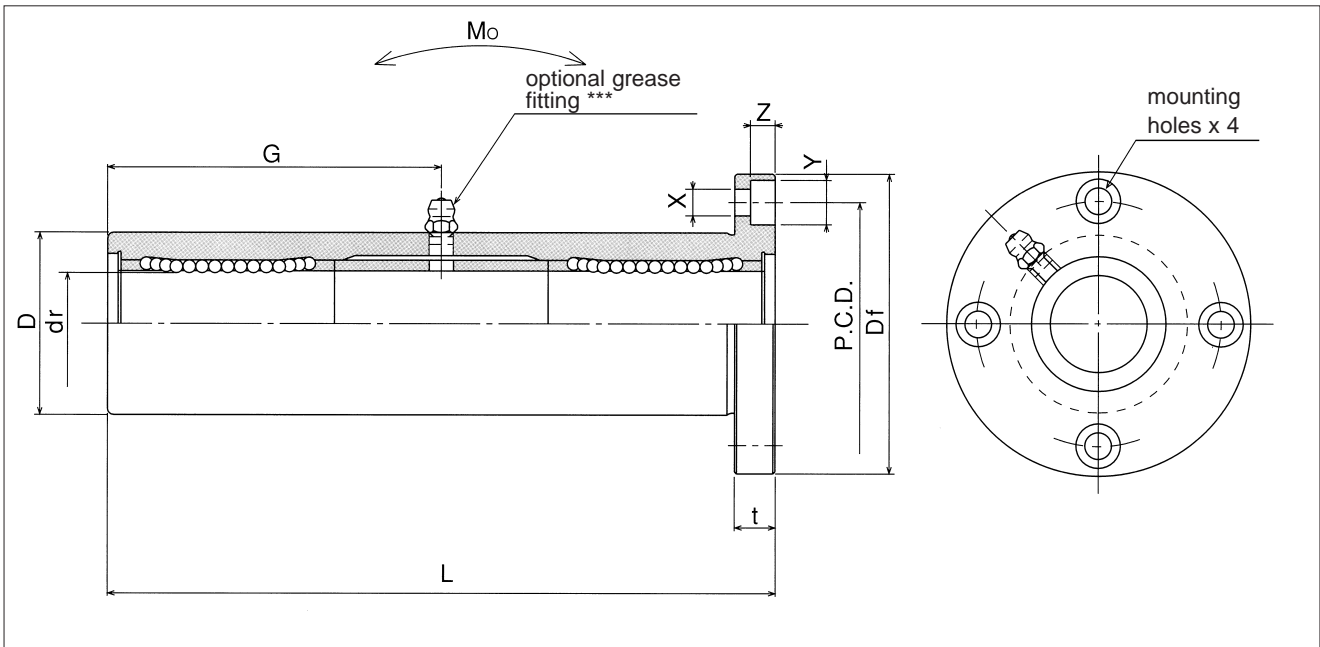

major dimensions			grease fitting	eccentricity	perpendicularity	basic load rating		allowable static moment	mass	shaft diameter
flange						G	dynamic			
t	P.C.D.	X×Y×Z	μm	μm	C			Co	Mo	g
5	24	3.5×6×3.1	20.5	20	20	323	530	8.2	66	6
6	29	4.5×7.5×4.1	29			431	784	16.0	135	8
6	33	4.5×7.5×4.1	38			588	1,100	27.0	205	10
6	36	4.5×7.5×4.1	41			813	1,570	40.1	248	12
6	38	4.5×7.5×4.1	45			813	1,570	42.9	308	13
8	43	5.5×9×5.1	51	25	25	1,230	2,350	73.5	412	16
8	51	5.5×9×5.1	59			1,400	2,740	98.0	752	20
10	60	6.6×11×6.1	82.5			1,560	3,140	157	1,244	25
10	67	6.6×11×6.1	91			2,490	5,490	297	1,636	30
13	78	9×14×8.1	100			2,650	6,270	373	2,580	35
13	83	9×14×8.1	115	30	30	3,430	8,040	553	2,950	40
18	107	11×17×11.1	145			6,080	15,900	1,370	6,860	50
18	122	11×17×11.1	155			7,550	20,000	1,800	9,660	60

1N≐0.102kgf 1N·m≐0.102kgf·m

TRK TYPE

– Triple-Wide Square Flange Type –

This type is a metric dimension series widely used in Japan and other countries.

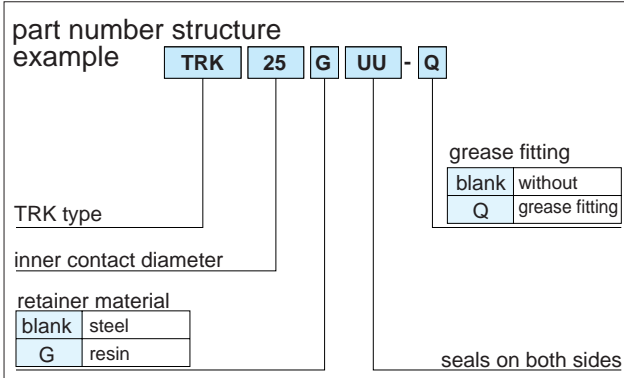
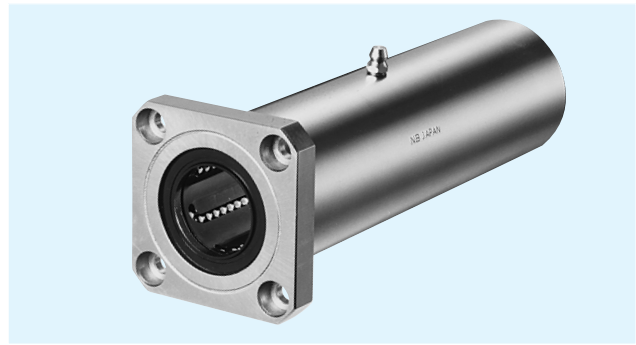

part number*		dr		D		L	Df
steel retainer	resin retainer	mm	tolerance μm	mm	tolerance μm	± 0.3 mm	mm
TRK 6UU	TRK 6GUU	6	0	15	0/-18	51	32
TRK 8UU	TRK 8GUU	8	-12	19	0	66	40
TRK10UU	TRK10GUU	10	-15	23		80	43
TRK12UU	TRK12GUU	12		0	26	-21	84
TRK13UU	TRK13GUU	13	-18	28	0	90	48
TRK16UU	TRK16GUU	16		32		103	54
TRK20UU	TRK20GUU	20	0	40	-25	118	62
TRK25UU	TRK25GUU	25	-21	45	0	165	74
TRK30UU	TRK30GUU	30		52		182	82
TRK35UU	TRK35GUU	35	0	60	-30	200	96
TRK40UU	TRK40GUU	40	-25	65	0	230	101
TRK50UU	TRK50GUU	50		85		290	129
TRK60UU	TRK60GUU	60	0/-25	100	-35	310	144

* UU type is standard feature.

** Outer cylinder is electroless nickel plated.

*** TRK6~8: A-MT6x1 TRK10~30: A-M6F TRK35~60: A-PT1/8

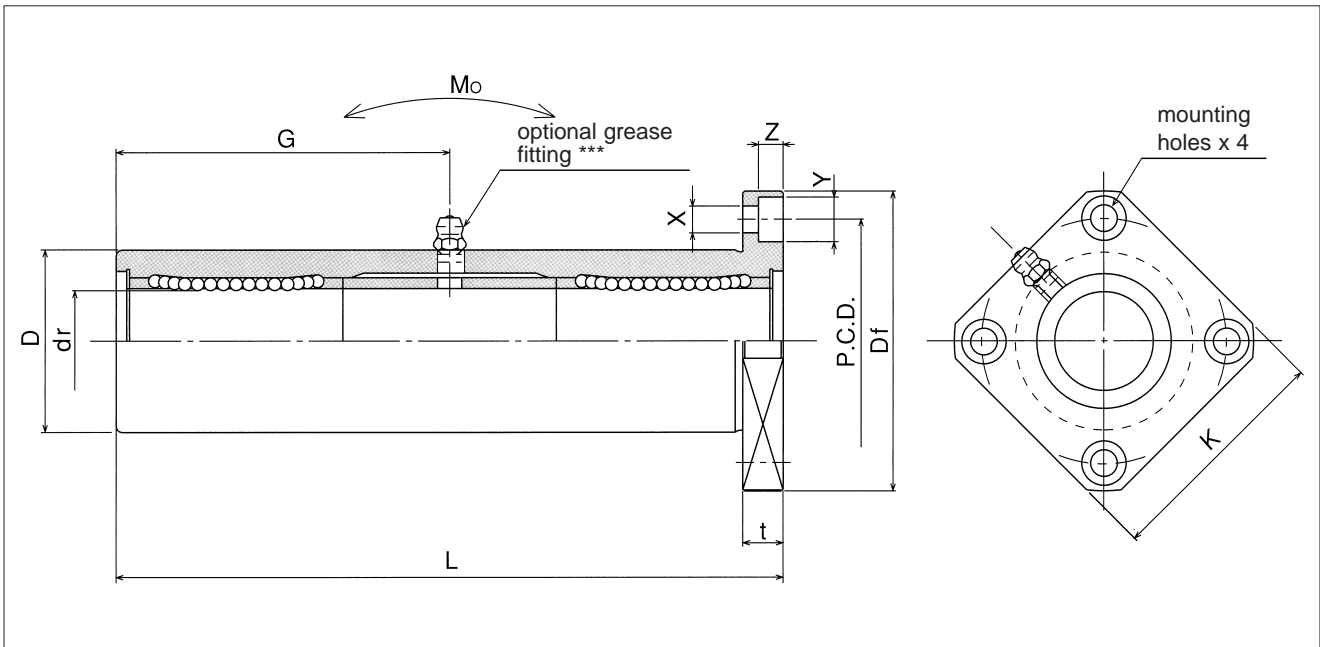

major dimensions				grease fitting	eccentricity	perpen- dicularity	basic load rating		allowable static moment	mass	shaft diameter
flange			G				dynamic	static			
K	t	P.C.D.		X×Y×Z	μm	μm			C	Co	Mo
25	5	24	3.5×6×3.1	20.5	20	20	323	530	8.2	58	6
30	6	29	4.5×7.5×4.1	29			431	784	16.0	117	8
34	6	33	4.5×7.5×4.1	38			588	1,100	27.0	189	10
35	6	36	4.5×7.5×4.1	41			813	1,570	40.1	228	12
37	6	38	4.5×7.5×4.1	45			813	1,570	42.9	286	13
42	8	43	5.5×9×5.1	51	25	25	1,230	2,350	73.5	376	16
50	8	51	5.5×9×5.1	59			1,400	2,740	98.0	714	20
58	10	60	6.6×11×6.1	82.5			1,560	3,140	157	1,163	25
64	10	67	6.6×11×6.1	91			2,490	5,490	297	1,543	30
75	13	78	9×14×8.1	100	30	30	2,650	6,270	373	2,400	35
80	13	83	9×14×8.1	115			3,430	8,040	553	2,510	40
100	18	107	11×17×11.1	145			6,080	15,900	1,370	6,400	50
116	18	122	11×17×11.1	155			7,550	20,000	1,800	9,200	60

1N ≅ 0.102kgf 1N·m ≅ 0.102kgf·m

TRFC TYPE

— Triple-Wide Intermediate Position Round Flange Type —

This type is a metric dimension series widely used in Japan and other countries.

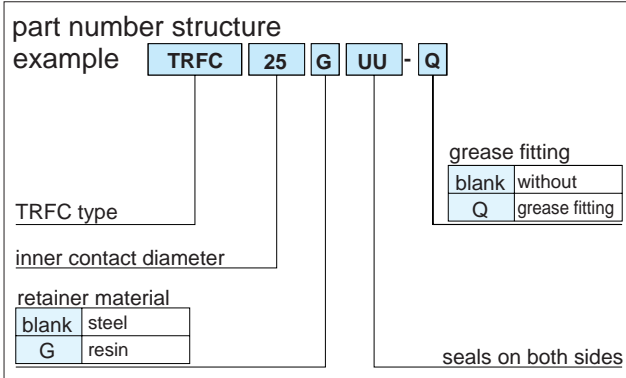

part number*							
steel retainer	resin retainer	dr		D		L	
		mm	tolerance μm	mm	tolerance μm	±0.3 mm	ℓ mm
TRFC 6UU	TRFC 6GUU	6	0	15	0/-18	51	17
TRFC 8UU	TRFC 8GUU	8	-12	19	0	66	22
TRFC10UU	TRFC10GUU	10	-15	23		80	27
TRFC12UU	TRFC12GUU	12		0	26	-21	84
TRFC13UU	TRFC13GUU	13	-18	28	0	90	30
TRFC16UU	TRFC16GUU	16		32		103	35
TRFC20UU	TRFC20GUU	20	0	40	-25	118	40
TRFC25UU	TRFC25GUU	25	-21	45	0	165	55
TRFC30UU	TRFC30GUU	30		52		182	61
TRFC35UU	TRFC35GUU	35	0	60	-30	200	67
TRFC40UU	TRFC40GUU	40	-25	65	0	230	77
TRFC50UU	TRFC50GUU	50		85		290	97
TRFC60UU	TRFC60GUU	60	0/-25	100	-35	310	104

* UU type seal is standard feature.

** Outer cylinder is electroless nickel plated.

*** TRFC6~8: A-MT6x1 TRFC10~30: A-M6F TRFC35~60: A-PT1/8

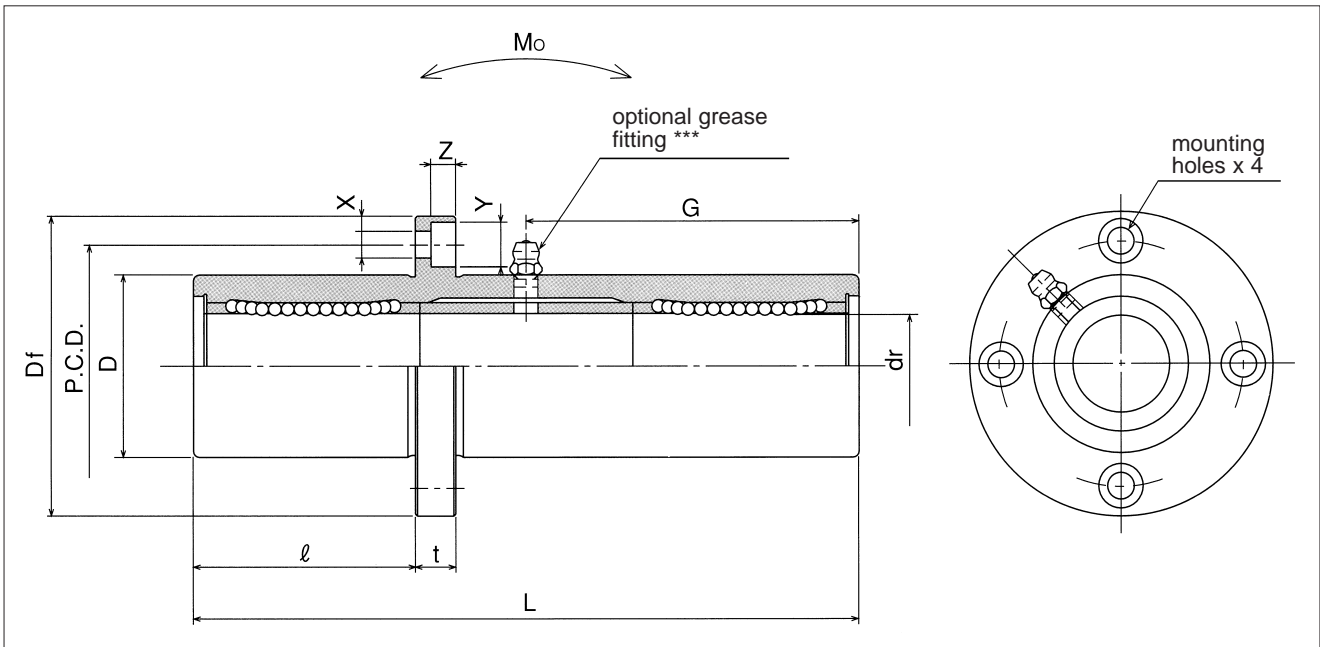

major dimensions				grease fitting G mm	eccentricity μm	perpen- dicularity μm	basic load rating		allowable static moment Mo N · m	mass g	shaft diameter mm
Df mm	t mm	P.C.D. mm	X × Y × Z mm				C N	Co N			
32	5	24	3.5 × 6 × 3.1	20.5	20	20	323	530	8.2	66	6
40	6	29	4.5 × 7.5 × 4.1	29			431	784	16.0	135	8
43	6	33	4.5 × 7.5 × 4.1	38			588	1,100	27.0	205	10
46	6	36	4.5 × 7.5 × 4.1	41			813	1,570	40.1	248	12
48	6	38	4.5 × 7.5 × 4.1	45			813	1,570	42.9	308	13
54	8	43	5.5 × 9 × 5.1	51	25	25	1,230	2,350	73.5	412	16
62	8	51	5.5 × 9 × 5.1	59			1,400	2,740	98.0	752	20
74	10	60	6.6 × 11 × 6.1	82.5			1,560	3,140	157	1,244	25
82	10	67	6.6 × 11 × 6.1	91			2,490	5,490	297	1,636	30
96	13	78	9 × 14 × 8.1	100	30	30	2,650	6,270	373	2,580	35
101	13	83	9 × 14 × 8.1	115			3,430	8,040	553	2,950	40
129	18	107	11 × 17 × 11.1	145			6,080	15,900	1,370	6,860	50
144	18	122	11 × 17 × 11.1	155			7,550	20,000	1,800	9,660	60

1N \approx 0.102kgf 1N · m \approx 0.102kgf · m

TRKC TYPE

— Triple-Wide Intermediate Position Square Flange Type —

This type is a metric dimension series widely used in Japan and other countries.

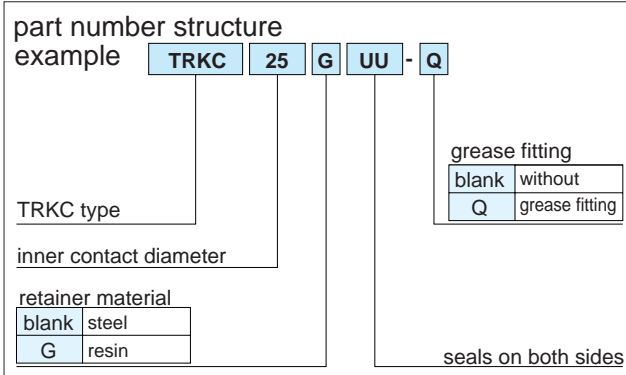

part number*							
steel retainer	resin retainer	dr		D		L	
		mm	tolerance μm	mm	tolerance μm	±0.3 mm	ℓ mm
TRKC 6UU	TRKC 6GUU	6	0	15	0/-18	51	17
TRKC 8UU	TRKC 8GUU	8	-12	19	0	66	22
TRKC10UU	TRKC10GUU	10	-15	23		80	27
TRKC12UU	TRKC12GUU	12		26		-21	84
TRKC13UU	TRKC13GUU	13	-18	28	0	90	30
TRKC16UU	TRKC16GUU	16		32		103	35
TRKC20UU	TRKC20GUU	20		40		118	40
TRKC25UU	TRKC25GUU	25	0	45	-25	165	55
TRKC30UU	TRKC30GUU	30	-21	52	0	182	61
TRKC35UU	TRKC35GUU	35		60		200	67
TRKC40UU	TRKC40GUU	40		65		-30	230
TRKC50UU	TRKC50GUU	50	-25	85	0	290	97
TRKC60UU	TRKC60GUU	60		100	-35	310	104

* UU type is standard feature.

** Outer cylinder is electroless nickel plated.

*** TRKC6~8: A-MT6x1 TRKC10~30: A-M6F TRKC35~60: A-PT1/8

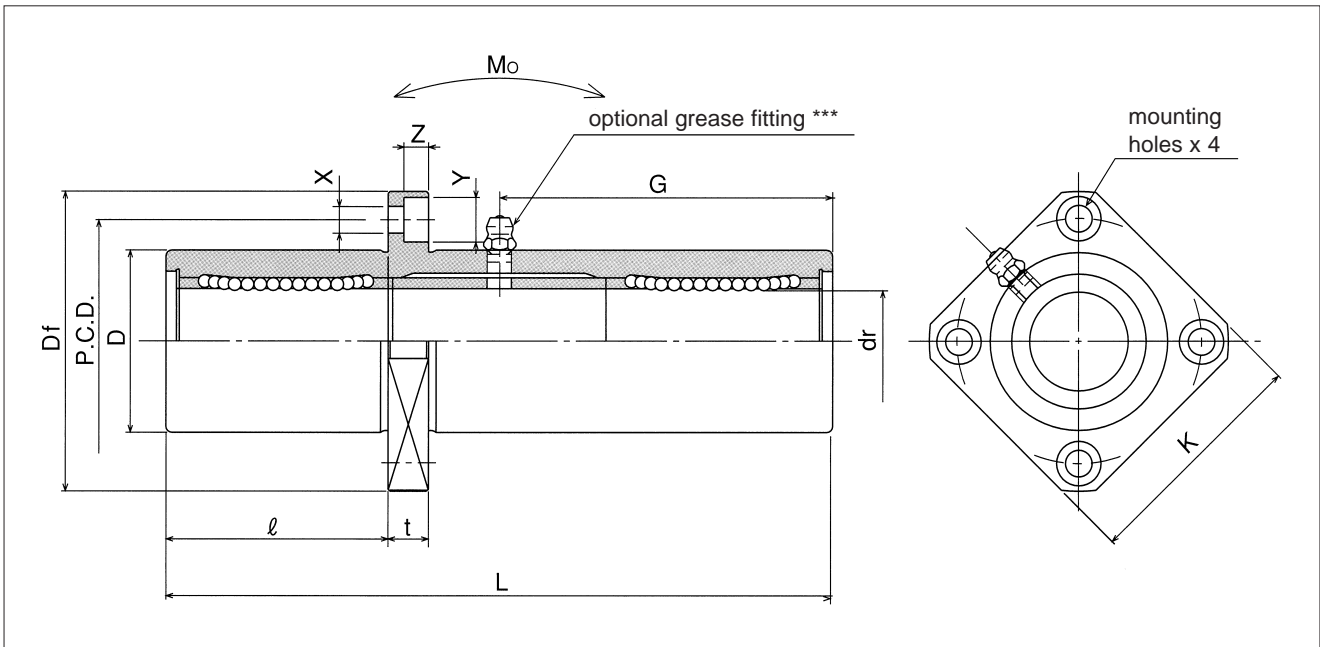

major dimensions					grease fitting G mm	eccentricity μm	perpendicularity μm	basic load rating		allowable static moment M_o $\text{N}\cdot\text{m}$	mass g	shaft diameter mm
flange								C	Co			
D_f mm	K mm	t mm	P.C.D. mm	X×Y×Z mm			N	N				
32	25	5	24	3.5×6×3.1	20.5	20	20	323	530	8.2	58	6
40	30	6	29	4.5×7.5×4.1	29			431	784	16.0	117	8
43	34	6	33	4.5×7.5×4.1	38			588	1,100	27.0	189	10
46	35	6	36	4.5×7.5×4.1	41			813	1,570	40.1	228	12
48	37	6	38	4.5×7.5×4.1	45			813	1,570	42.9	286	13
54	42	8	43	5.5×9×5.1	51	25	25	1,230	2,350	73.5	376	16
62	50	8	51	5.5×9×5.1	59			1,400	2,740	98.0	714	20
74	58	10	60	6.6×11×6.1	82.5			1,560	3,140	157	1,163	25
82	64	10	67	6.6×11×6.1	91			2,490	5,490	297	1,543	30
96	75	13	78	9×14×8.1	100			2,650	6,270	373	2,400	35
101	80	13	83	9×14×8.1	115	30	30	3,430	8,040	553	2,510	40
129	100	18	107	11×17×11.1	145			6,080	15,900	1,370	6,400	50
144	116	18	122	11×17×11.1	155			7,550	20,000	1,800	9,200	60

1N \approx 0.102kgf 1N·m \approx 0.102kgf·m

TRF-E TYPE

— Triple-Wide Round Flange Pilot End Type —

This type is a metric dimension series widely used in Japan and other countries.

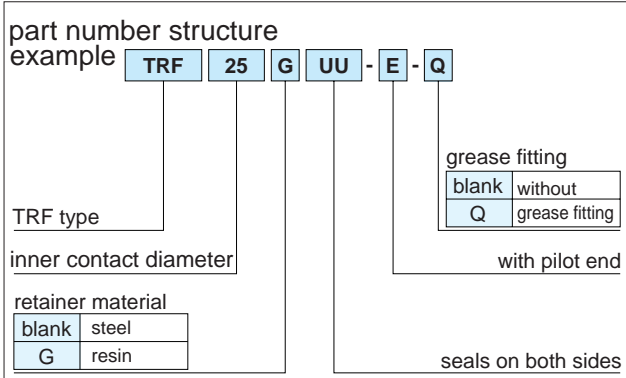

part number*		dr		D		L	∅
steel retainer	resin retainer	mm	tolerance μm	mm	tolerance μm	±0.3 mm	mm
TRF 6UU-E	TRF 6GUU-E	6	0	15	0/-18	51	5
TRF 8UU-E	TRF 8GUU-E	8	-12	19	0	66	6
TRF10UU-E	TRF10GUU-E	10		23		80	6
TRF12UU-E	TRF12GUU-E	12	0	26	-21	84	6
TRF13UU-E	TRF13GUU-E	13	-15	28	0	90	6
TRF16UU-E	TRF16GUU-E	16		32		103	8
TRF20UU-E	TRF20GUU-E	20	0	40	-25	118	8
TRF25UU-E	TRF25GUU-E	25	-18	45	0	165	10
TRF30UU-E	TRF30GUU-E	30		52		182	10
TRF35UU-E	TRF35GUU-E	35	0	60	-30	200	13
TRF40UU-E	TRF40GUU-E	40	-21	65	0	230	13
TRF50UU-E	TRF50GUU-E	50		85		290	18
TRF60UU-E	TRF60GUU-E	60	0/-25	100	-35	310	18

* UU type is standard feature.

** Outer cylinder is electroless nickel plated.

*** TRF6~8-E: A-MT6x1 TRF10~30-E: A-M6F TRF35~60-E: A-PT1/8

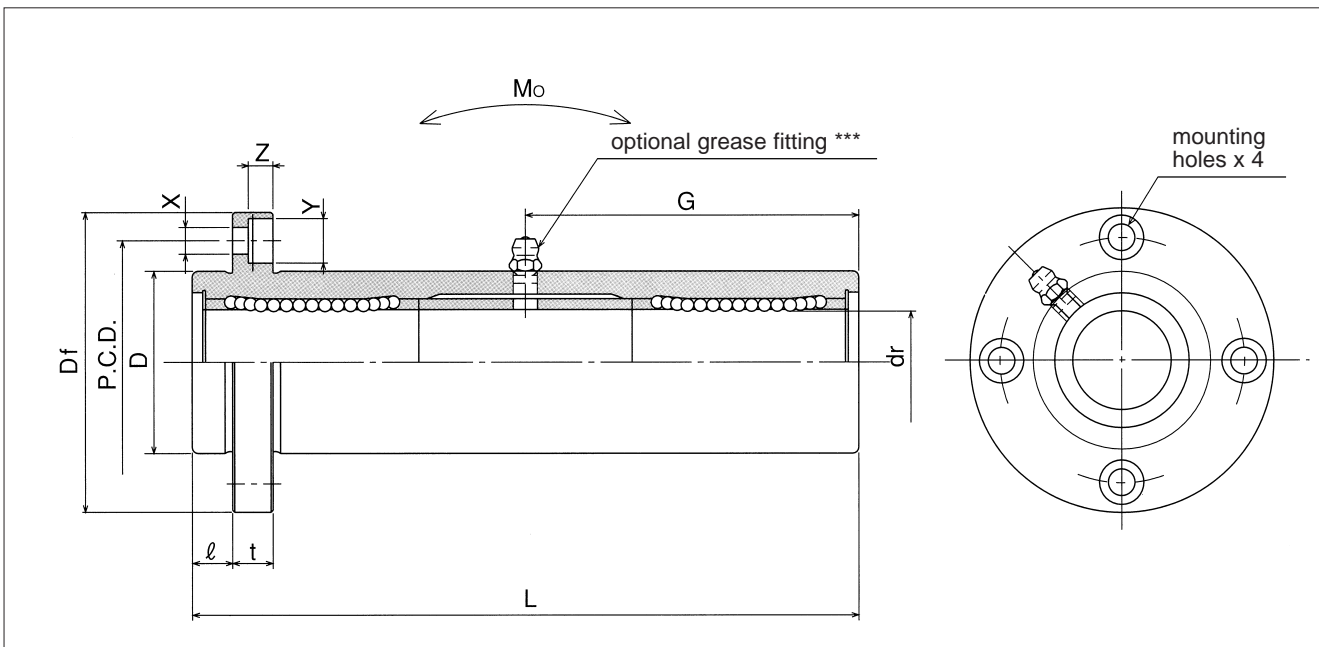

major dimensions				grease fitting G mm	eccentricity μm	perpen- dicularity μm	basic load rating		allowable static moment M_o N · m	mass g	shaft diameter mm
Df mm	t mm	P.C.D. mm	X×Y×Z mm				dynamic C N	static Co N			
32	5	24	3.5×6×3.1	20.5	20	20	323	530	8.2	66	6
40	6	29	4.5×7.5×4.1	29			431	784	16.0	135	8
43	6	33	4.5×7.5×4.1	38			588	1,100	27.0	205	10
46	6	36	4.5×7.5×4.1	41			813	1,570	40.1	248	12
48	6	38	4.5×7.5×4.1	45			813	1,570	42.9	308	13
54	8	43	5.5×9×5.1	51	25	25	1,230	2,350	73.5	412	16
62	8	51	5.5×9×5.1	59			1,400	2,740	98.0	752	20
74	10	60	6.6×11×6.1	82.5			1,560	3,140	157	1,244	25
82	10	67	6.6×11×6.1	91			2,490	5,490	297	1,636	30
96	13	78	9×14×8.1	100	30	30	2,650	6,270	373	2,580	35
101	13	83	9×14×8.1	115			3,430	8,040	553	2,950	40
129	18	107	11×17×11.1	145			6,080	15,900	1,370	6,860	50
144	18	122	11×17×11.1	155			7,550	20,000	1,800	9,660	60

1N \approx 0.102kgf 1N·m \approx 0.102kgf·m

TRK-E TYPE

– Triple-Wide Square Flange Pilot End Type –

This type is a metric dimension series widely used in Japan and other countries.

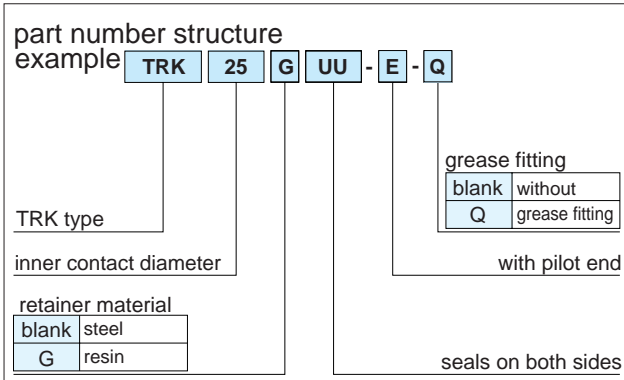
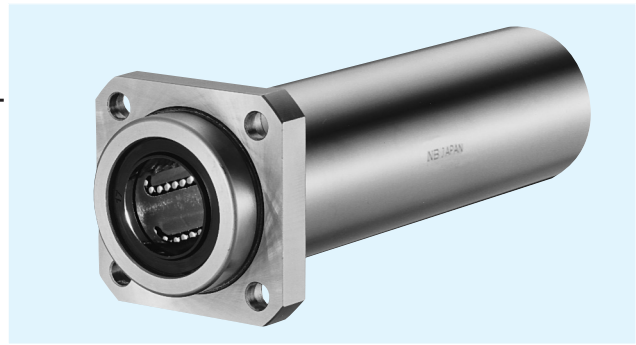

part number*							
steel retainer	resin retainer	dr		D		L	ℓ
		mm	tolerance μm	mm	tolerance μm	±0.3 mm	
TRK 6UU-E	TRK 6GUU-E	6	0	15	0/-18	51	5
TRK 8UU-E	TRK 8GUU-E	8	-12	19	0	66	6
TRK10UU-E	TRK10GUU-E	10	-15	23		80	6
TRK12UU-E	TRK12GUU-E	12		0	26	-21	84
TRK13UU-E	TRK13GUU-E	13	-18	28	0	90	6
TRK16UU-E	TRK16GUU-E	16		32		103	8
TRK20UU-E	TRK20GUU-E	20	0	40	-25	118	8
TRK25UU-E	TRK25GUU-E	25	-21	45	0	165	10
TRK30UU-E	TRK30GUU-E	30		52		182	10
TRK35UU-E	TRK35GUU-E	35	0	60	-30	200	13
TRK40UU-E	TRK40GUU-E	40	-25	65	0	230	13
TRK50UU-E	TRK50GUU-E	50		85		290	18
TRK60UU-E	TRK60GUU-E	60	0/-25	100	-35	310	18

* UU type is standard feature.

** Outer cylinder is electroless nickel plated.

*** TRK6-8-E: A-MT6x1 TRK10-30-E: A-M6F TRK35-60-E: A-PT1/8

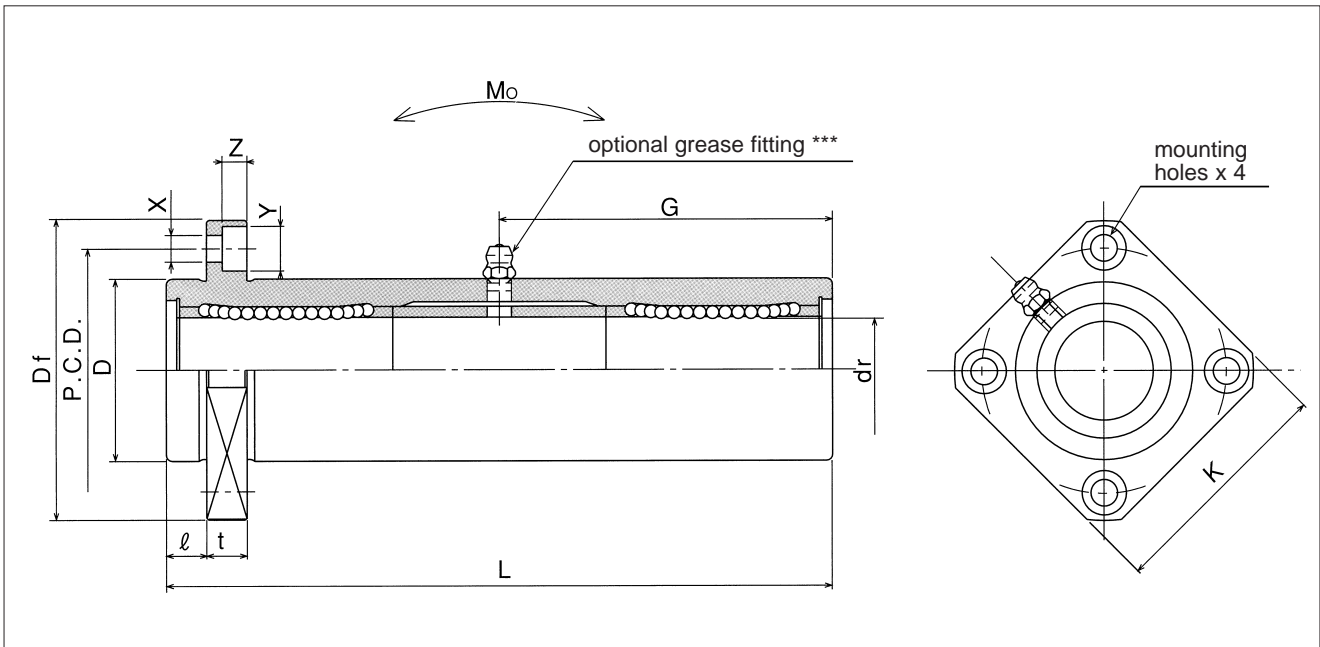

major dimensions					grease fitting G mm	eccentricity μm	perpendicularity μm	basic load rating		allowable static moment Mo N·m	mass g	shaft diameter mm
flange								C	Co			
Df mm	K mm	t mm	P.C.D. mm	X×Y×Z mm			N	N				
32	25	5	24	3.5×6×3.1	20.5	20	20	323	530	8.2	58	6
40	30	6	29	4.5×7.5×4.1	29			431	784	16.0	117	8
43	34	6	33	4.5×7.5×4.1	38			588	1,100	27.0	189	10
46	35	6	36	4.5×7.5×4.1	41			813	1,570	40.1	228	12
48	37	6	38	4.5×7.5×4.1	45			813	1,570	42.9	286	13
54	42	8	43	5.5×9×5.1	51	25	25	1,230	2,350	73.5	376	16
62	50	8	51	5.5×9×5.1	59			1,400	2,740	98.0	714	20
74	58	10	60	6.6×11×6.1	82.5			1,560	3,140	157	1,163	25
82	64	10	67	6.6×11×6.1	91			2,490	5,490	297	1,543	30
96	75	13	78	9×14×8.1	100			2,650	6,270	373	2,400	35
101	80	13	83	9×14×8.1	115	30	30	3,430	8,040	553	2,510	40
129	100	18	107	11×17×11.1	145			6,080	15,900	1,370	6,400	50
144	116	18	122	11×17×11.1	155			7,550	20,000	1,800	9,200	60

1N \approx 0.102kgf 1N·m \approx 0.102kgf·m